

LV Motors: Hazardous Area Application IE3 Energy Efficiency Series

Safe | Reliable | Long-lasting

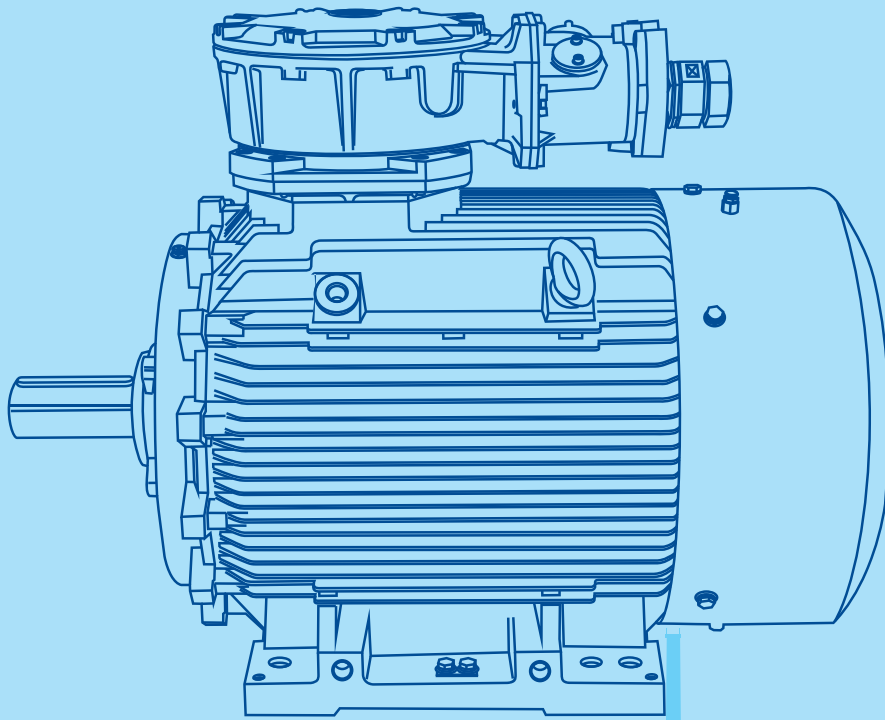

BHARAT BIJLEE MOTORS: MILESTONES

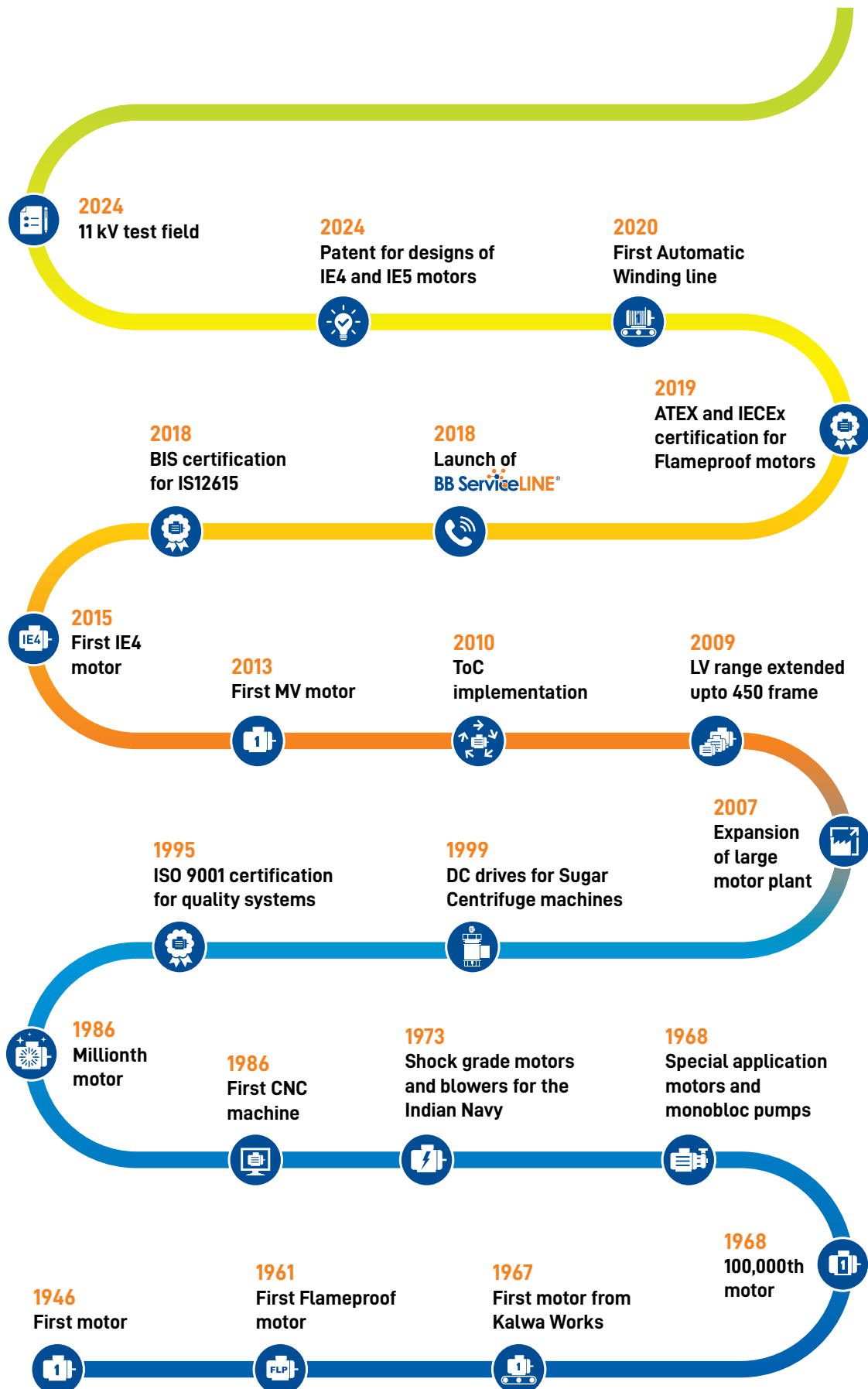

CONTENT

LV Hazardous Area Motors: An Introduction	1
IE3 Flame Proof Motors: Type Ex 'd'	2
A. Technical Information	3-8
Industrial Applications, Reference Standards, Statutory Approvals and Licenses	
Temperature Class, Electrical Features and Mechanical Features	
B. General Specifications: Standard and Optional Features	9
C. Performance Data: Standard Range of FLP Motors	10-13
D. Dimensional Drawing: Standard Range of FLP Motors	14-17
Certifications	18
LV Motors Product Range	19-20
Motors, Drive & Automation Solutions	21

LV HAZARDOUS AREA MOTORS: An Introduction

In specific scenarios, hazardous environment cannot be avoided and hence machines and processes have to be appropriately designed, to not only mitigate the risks but also avoid untoward incidents.

Motors are also used in applications in hazardous areas, thus creating a need for a very specific design suitable to such conditions. Hazardous areas are defined as those where explosive atmosphere is present, or is expected to be present, in quantities which merit the requirement of special precautions. The

construction, installation and use of equipment is designed specifically to suit the hazardous environment. The decision as to whether an area is hazardous as per the relevant regulations and specifications, rests entirely with the user, or in case of doubt, with the competent and authorized inspecting authority. IS 5572 classifies hazardous areas into three zones, depending on the frequency and duration for which dangerous concentrations are likely to be present.

Zone	Classification of area as per IS 5572	Selection of electrical equipment as per IS 16724
Zone '0'	An area in which hazardous atmosphere is continuously present.	Generally, use of electrical equipment is to be avoided. But when this is not practicable, intrinsically safe or pressurized electrical equipment to be used.
Zone '1'	Hazardous atmosphere is likely to be present under normal operating conditions.	For this area, electrical equipment used, must be in flame proof enclosure type Ex 'd' conforming to IS/IEC 60079-1.
Zone '2'	In this area, hazardous atmosphere is likely to be present only under abnormal operating conditions and for a short period.	Apparatus with type of protection Ex eb in accordance with IS/IEC 60079-7 may be used without any special enclosure. Apparatus having type of protection Ex ec in accordance with IS/IEC 60079-7 are also permitted for use.

Why Bharat Bijlee?

Bharat Bijlee offers a wide range of hazardous area motors.



Increased Safety Ex ec and Flame Proof Ex 'd' motors across different efficiency levels



ATEX / IECEx certification for Flame Proof Ex 'd' motors



Flame Proof Ex 'd' motors for Zone '1', '21' & '22' & Increased Safety Ex ec motors for Zone '2' & '22'



Licensed by BIS as per statutory requirement



Flame Proof Ex 'd' motors suited for temperature class T4, T5 & T6 and increased Safety Ex ec motors for temperature class T3



Motors with certified test reports from PESO approved test laboratory



PESO certification



Accessories and customizations as per customers' requirements adhering to necessary statutory requirements

Bharat Bijlee's motors for hazardous area have been widely used across various sectors such as Oil & Gas, Pharmaceutical, Mining, Chemical & Power and have been successfully working on all possible applications over the years. These motors have been trusted for critical applications that require adherence to

extremely stringent norms. Our annual production capacity is backed by an indigenous state-of-the-art manufacturing facility. With rigorous quality checks at various stages in our factory, we deliver some of the finest and most reliable motors in the industry.

IE3 FLAME PROOF MOTORS: Type Ex 'd'

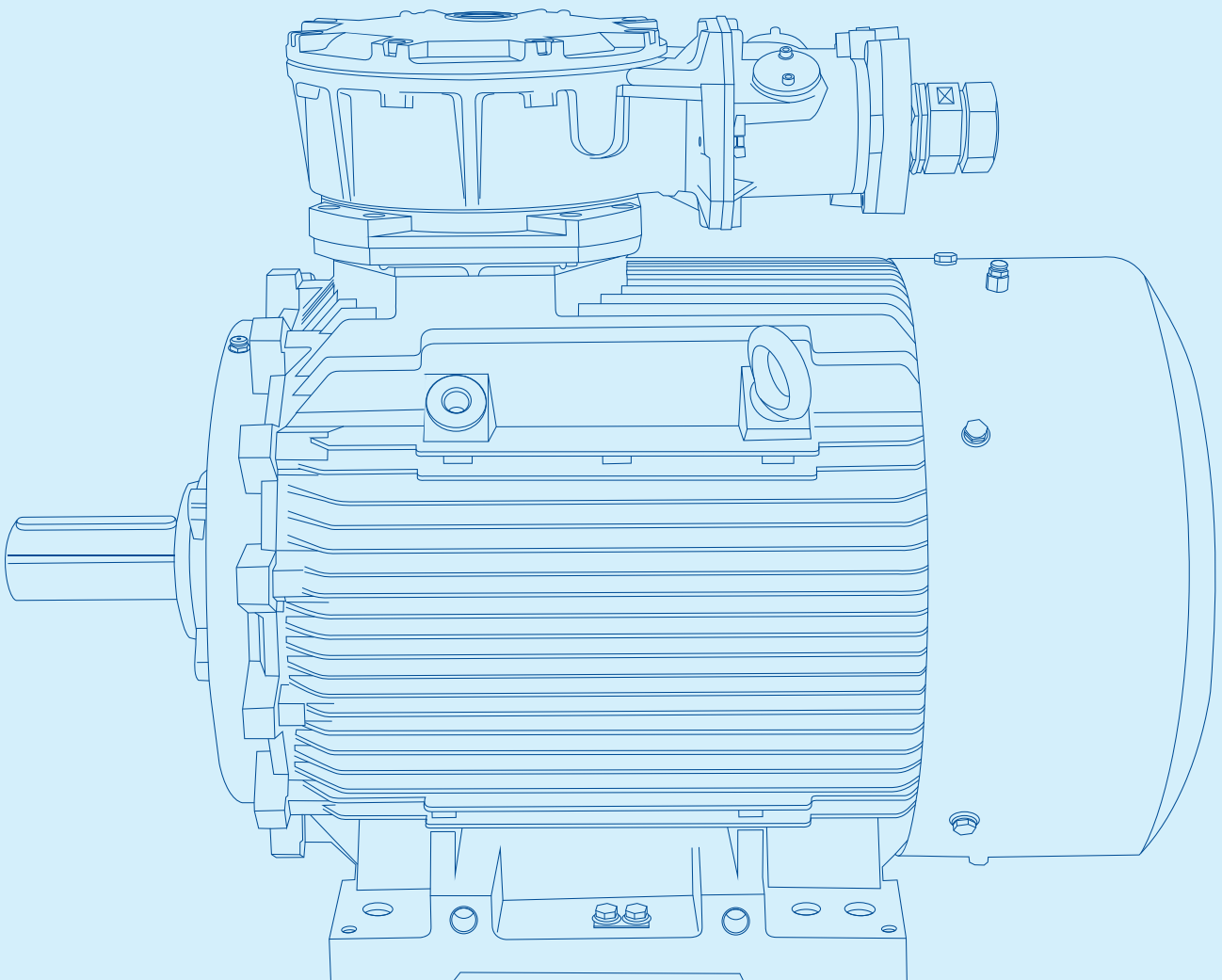

IE3 FLAME PROOF MOTORS: Type Ex 'd'

A. Technical Information

A.1 Industrial Applications



Coal
Mines



Petro
Chemicals
& Chemicals



Oil Mines
& Rigs



Fertilizers



Solvent
Extraction
Plant



Paints &
Varnish
Industry



LPG
Bottling
Plants



Agro
Chemicals



Drugs &
Pharmaceuticals



General
Industry

A.2 Reference Standards

IS/IEC 60079-0	Electrical apparatus for explosive gas atmosphere-Part 0 General Requirements
IS/IEC 60079-1	Electrical apparatus for explosive gas atmosphere-equipment protection by Flame Proof Enclosures "d"
IS 5572	Classification of hazardous areas (other than mining) having flammable gases and vapors for electrical installations
IS 16724	Explosive atmospheres - Electrical Installations Design, Selection and Erection
IS 15999 : Part 1	Rotating Electrical Machines - Part 1 : Rating and Performance
IS 12615	Line Operated Three Phase A.C. Motors (IE CODE) "Efficiency Classes and Performance Specification"
IS 4029	Guide for testing Three Phase Induction Motors (For Standard TEFC SCR Motors)
IS 4889	Methods of determination of efficiency of Rotating Electric Machines (For Standard TEFC SCR Motors)
IS 15999 - (Part 2/Sec 1)	Standard methods for determining losses and efficiency from tests (For IE Series Motors)
IS/IEC 60034-5	Degree of protection provided by the integral design of Rotating Electrical Machines (IP code Classification)
IS 6362/IEC 60034-6	Designation of method of cooling for Rotating Electrical Machines/method of cooling (IC code)
IS 12065	Permissible limits of noise level for Rotating Electrical Machines
IS 12075	Mechanical Vibration of Rotating Electrical Machines
IS 8223	Dimension and Output rating of Rotating Electrical Machines
IS 900	Code of practice for installation and maintenance of Induction Motors
IS 1231	Dimensions of Foot Mounted AC Induction Motors
IS 2223	Dimensions of Flange Mounted AC Induction Motors

A.3 Statutory Approvals and Licenses

Motors used in hazardous areas need statutory approvals from various authorities depending upon their area of jurisdiction before marketing. Statutory / Licensing authorities accord their approval / license based on the test reports issued by their recognized test houses such as CIMFR Dhanbad, ERTL (East) Kolkata etc.

Statutory Authority	Scope	Area of Jurisdiction
PESO Approved Test Laboratory	Testing and Certification	
Petroleum & Explosives Safety Organization (PESO), Nagpur (formerly CCoE)	Approving	All areas where explosive liquids/gases are stored and transported
Bureau of Indian Standards (BIS)	Licensing	

All Flame Proof Motors have license mark IS/IEC 60079-1.

IE3 FLAME PROOF MOTORS: Type Ex 'd'

A.4 Temperature Class

The classification of temperature class T1 to T6 is as mentioned below:

Temperature Class as required by the area classification	Maximum Surface Temperature in °C	Allowable Temperature Classes of equipment
T1	≤ 450	T1 to T6
T2	≤ 300	T2 to T6
T3	≤ 200	T3 to T6
T4	≤ 135	T4 to T6
T5	≤ 100	T5 to T6
T6	≤ 85	T6

The maximum surface temperature under the worst operating condition must not exceed the ignition temperature of gas. The maximum surface temperature refers to that surface which comes in contact with the explosive gas. In case of Flame Proof Ex 'd' motors, this refers to external surface temperature, whereas in case of Increased Safety Ex ec motors, this refers to the internal temperature as well.

Temperature Class of Bharat Bijlee Motors

Frame Size		Temperature Class
IEC Frame Size	Pole	
80	2, 4, 6, 8	T6
90L	2, 4, 6, 8	T5
90L	2(2.2kW)	T6
	4(1.5kW)	
	6(1.1kW)	
100L	2, 4, 6, 8	T5
112L	2, 4, 6, 8	T5
132 S/M	2, 4, 6, 8	T5
160M/L	2, 4, 6, 8	T5
180M/L	2, 4, 6, 8	T5
200L	2, 4, 6, 8	T5
225S/M	2, 4	T4
	6, 8	T5
250M	2, 4	T5
	6, 8	T4
280S/M	2, 4, 6, 8	T4
315S/M/L	2, 4, 6, 8	T4
355	MJ355	T4

Classification of Hazardous Gases

Our Flame Proof motors are offered suitable for gas group I, IIA and IIB only. List of hazardous gases, their group specification and ignition temperatures have been specified in IS/IEC 60079-20. Some of the gases are listed in the following table.

Gas Group	Gas or Vapour	Temperature Class
I	Methane (firedamp)	T1
	Industrial Methane*	T1
IIA	Carbon monoxide	T1
	Decane	T3
	Xylene	T1
	Methyl acetate	T1
	Hexane	T3
	Heptane	T3
	Iso-octane	T2
	Propane	T1
	Butane	T2
	Benzene	T1
	Cyclohexane	T2
	Acetone	T1
	Ethyl acetate	T1
	Chloroethylene	T1
	Methanol	T1
	Ethanol	T2
	IIB	Butyl acetate
1,3-Butadiene		T2
Ethylene		T2
Diethyl ether		T4
Ethylene oxide		T2
IIC	Coke-oven Gas	T1
	Hydrogen	T1
	Acetylene	T1

***Note:** Industrial Methane includes Methane mixed with not more than 10% volume of Hydrogen.

IE3 FLAME PROOF MOTORS: Type Ex 'd'

A.5 Electrical Features

Standard Operating Conditions

- Voltage: 415V ± 10%
- Frequency: 50 Hz ± 5%
- Combined Variation: ± 10% (absolute sum with maximum frequency variation 5%)
- Ambient: 45°C
- Altitude: upto 1000m above mean sea level

Re-Rating factors applicable under different conditions of Ambient and Altitude

I. Variation in Ambient

Ambient Temperature (°C)	Permissible Output as % of Rated Value
30 to 45	100
50	96
55	92
60	87

II. Variation in Altitude

Altitude above Mean Sea Level (m)	Permissible Output as % of Rated Value
1000	100
1500	97
2000	94
2500	90
3000	86
3500	82
4000	77

Method of Starting

kW Rating	Method of Starting	No. of Leads
Upto & including 1.5 kW	DOL	3 (Internal Star Connection)
Above 1.5 kW	DOL or Star / Delta	6

Starting Current Measurement

Induction motor starting current is generally 6 to 7 times the full load current of the motor. This is a characteristic feature of the motor and though undesirable, it is inevitable in the design of the motor.

Measurement of this starting current at rated voltage becomes difficult since it demands higher capacity of the supply system as well as use of appropriate CTs in the circuit of meters. Generally a fraction of rated starting current is passed in the motor due to capacity constraints. This current is extrapolated to rated voltage.

kW Range	Measurement at % of Voltage to Rated Voltage
0.12 kW to 90 kW	70 %
90 kW to 200 kW	60 %
200 kW to 315 kW	35 %

Duty, Starting Time and Number of Consecutive Starts

For load $GD^2 \leq$ Motor GD^2 , the motors can safely withstand 3 consecutive starts from cold condition and 2 consecutive starts from hot condition. In application where more severe starting conditions are encountered, a special enquiry should be made to our Sales Office. e.g.

- Drives with high inertia e.g flywheel drives, eccentric presses, large fans, etc.
- Drives involving intermittent duty of motors with frequent starts e.g. rolling mills, centrifuges and conveyor motors, etc.

The enquiry should be accompanied with following information:

- GD^2 and relevant speed of driven equipment
- Duty cycle / sequence of operation / no. starts / hour
- Speed-Torque diagram of driven equipment
- Method of braking (Electrical or Mechanical)
- Method of starting
- Method of coupling

Insulation for Converter Fed Motors

- Converter fed motors are provided with special insulation scheme to take care of voltage surges in the supply voltage.
- Depending on the voltage wave rise time (dV/dt) and the maximum peak to peak voltage at the motor terminals, suitable insulation schemes are provided on request.
- On customer's demand, insulated bearings are offered from frame size 160 onwards on the non driving end side of the motor.

Earthing Terminals

Two earthing terminals are provided, one on each motor foot. Also, two earthing terminals are provided in the terminal box.

IE3 FLAME PROOF MOTORS: Type Ex 'd'

A.6 Mechanical Features

Enclosure and Cooling

These motors are so designed that the frame temperature will remain below the ignition temperature of gas-air mixture involved. The frame, end shields, terminals boxes and bearing covers of all motors are made of grey cast iron. All cast iron parts forming flame proof enclosures are subjected to hydraulic pressure test, after final machining as per IS/IEC 60079-1.

All motors are Totally Enclosed Fan Cooled (TEFC). The cooling is affected by self-driven, bi-directional cast iron or fabricated centrifugal fan protected by fan cover. The type of cooling is IC 411 as per IS 6362/IEC 60034-6. Minimum cooling distance as indicated in GA drawing has to be provided for effective cooling of the motor.

Degree of Protection

All motors have IP55 Degree of protection as per IS/IEC 60034-5. Higher degree of protection can be provided on request. All flanged motors are additionally provided with oil tight shaft protection on driving end side. A drain plug is not permissible in FLP motors.

Mounting

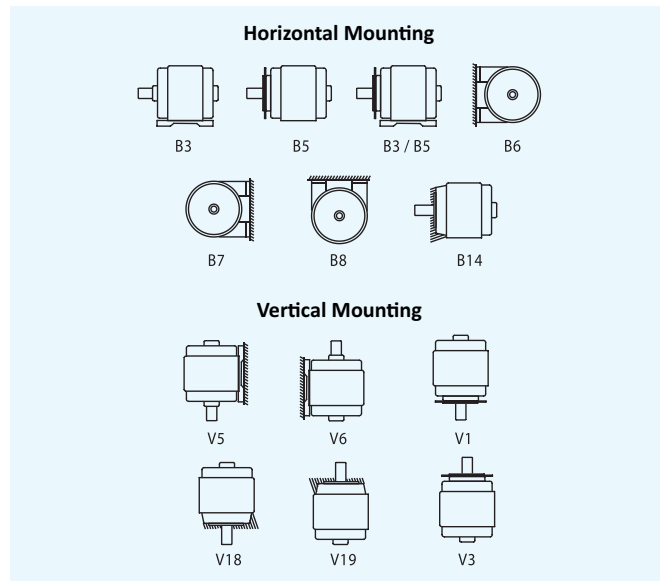

Standard motors are designed for foot mounting (B3). All foot mounted motors are with integral feet construction. These are also suitable for B6, B7, B8, V5 and V6 mounting without any change. Motors can be supplied in Flange mounting (B5). These are also suitable for V1 mounting.

Direction of Rotation

All motors are suitable for bi-directional rotation.

Balancing and Vibration

Rotors are dynamically balanced with a half key in the shaft extension. The balancing grade is G2.5 as per ISO:21940. Vibration grade is 'Normal grade' conforming to IS 12075. Other grades as per IS 12075 can be provided on request.

Motors are designed for noise level well below the limits specified in IS 12065.

Lifting Arrangement

All motors are provided with lifting hooks. When two or more hooks are provided, all hooks to be used simultaneously for lifting the motor.

Paint

All motors are given a special treatment of primer and paint to internal as well as external surface. All external surfaces are coated with epoxy polyamide base acid/alkali resistant paint of dark Admiralty Grey Shade (No. 632 as per IS: 5).

Name Plate

Stainless steel name plate is provided on each motor. Data such as gas group, temperature class and statutory approval references are provided with usual nameplate details.



IE3 FLAME PROOF MOTORS: Type Ex 'd'

Bearing and Terminal Box Details

Frame Size	Bearing Nos. C3 Clearance		Terminal Box Type	Terminals		Cable Entries No & Size **	Maximum Conductor Cross Sectional Area (mm ²)
	D.E.	N.D.E.		Nos	Size		
80	6204 2Z	6204 2Z	MJ80	3	M5	1 x M20	1R X 3CX4
90	6205 2Z	6205 2Z	MJ132	3/6*	M6	1 x M25	1RX3CX16
100	6206 2Z	6206 2Z					
112	6206 2Z	6206 2Z					
132	6208 2Z	6208 2Z					
160	6209 2Z	6209 2Z	MJ200	6	M8	2 x M25	2RX3CX35
180	6310 2Z	6310 2Z					
200	6212 2Z	6212 2Z	MJ280	6	M12	2 x M40	2RX3CX95
225	6213	6213					
250	6215	6215					
280 (2 Pole)	6316	6316					
280 (4, 6, 8 Pole)	6317	6316	MJ315	6	M16	2 x M50	2RX3CX185
315S/M & L	6319	6319					
355L (2Pole)	6319	6319	MJ315	6	M16	2 x M50	2RX3CX185
355L (4,6 & 8Pole)	6322	6322					

* 3 terminals up to and including 1.5 kW and 6 terminals for higher kW output.

** Cable entries other than those mentioned in the table can be offered subject to availability of statutory approval.

Note

- 1) L10 bearing life is 50,000 hours for directly coupled loads through flexible couplings only.
- 2) Standard terminal box location is TOP.
- 3) Sealed bearing (2Z) is filled with Lithium Soap based grease. Open bearings are filled with SKF LGMT3/ Unirex N3- ESSO grease.

Re-lubrication Interval

Bearing	Pole	Re-lubrication	
		Quantity (g)	Interval (Hrs)
6213	2	120	3200
	4		9000
	6		15000
	8		21000
6215	2	150	2800
	4		8200
	6		10000
	8		18000
6316	2	180	2000
	4		7500
	6		12500
	8		16500
6317	4	220	7500
	6		13000
	8		17500
6319	2	220	2000
	4		5000
	6		7500
	8		10000

Cable Entries

Motor for mining application (i.e. coal mines and oil mines) is provided with compound filling sealing box. Cable entries suitable for flame proof glands (for application in hazardous area Gas Group IIA and IIB only) can be provided with flame proof glands. A cable sealing box is mandatory for all motors for use in coal mines and oil mines.



IE3 FLAME PROOF MOTORS: Type Ex 'd'

Shipping Dimension

Frame	Packing Box Dimensions (mm)				Motor Gross Weight (kg)
	Pole	Length	Width	Height	
80	2, 4, 6, 8	440	440	310	33
80	2(1.1kW)	510	445	345	34
	4(0.55kW)				
	6(0.55kW)				
90L	2, 4, 6, 8	510	470	340	48
90L	2(2.2kW)	505	565	350	52
	4(1.5kW)				
	6(1.1kW)				
100L	2, 4	640	420	560	66
100L	6, 8	575	575	360	64
112M	2, 4, 6, 8	640	620	560	73
132S/M	2, 4, 6, 8	610	330	485	89
132S/M	2(7.5kW)	765	330	485	118
	4(7.5kW)				
	6(5.5kW)				
160M/L	2, 4, 6, 8	790	440	540	216
160M/L	2(18.5kW)	840	440	540	220
	6(11kW)				
180M/L	2, 4, 6, 8	940	440	635	320
200L	2, 4, 6, 8	940	540	690	408
225S/M	2, 4, 6, 8	920	540	790	534
250M	2, 4, 6, 8	1100	660	820	696
280S/M	2, 4, 6, 8	1220	660	890	860
315S/M	2, 4, 6, 8	1300	870	1000	1120
315L	2, 4, 6, 8	1500	870	1003	1625
355L	2, 4, 6, 8	1950	1150	1600	3175

Special Features

- Sturdy housing that prevents an internal explosion from spreading to the external environment and also resists the explosion pressure.
- Robust bearing shields and caps bolted to the frame in a manner where the gaps remain unaffected in the event of an internal explosion.
- Screen on air intake with a mesh size not exceeding 8mm.
- External two earth terminals on motor feet.
- Protective earth conductor terminal in the terminal box.
- Ex 'd' mark on the motors.
- Special insulation treatment and painting treatment to resist highly corrosive atmosphere.
- All vertical mounted motors will be provided with 3 lifting lugs.

Special Maintenance Care During Operation

Each motor must be provided with protective circuit breaker or an equally effective device. In order to maintain safety protection, the following care must be taken on site during operation:

- The joint faces must not be re-machined nor finished or coated with varnish or paint. The surfaces must be kept metallically clean. A thin film of grease must be applied as protection against rust. The use of gaskets at point where there were originally none, is not permitted.
- Defective mounting screws and bolts must be replaced promptly by new ones of a material with same tensile-strength as the original ones.
- Care should be taken to see that all screws, bolts, nuts etc, used for fixing the parts of flame proof enclosure are provided with spring washer wherever originally supplied, to prevent them from getting loose due to shocks and vibration during operation.
- Enough ventilating space must be provided for efficient cooling of the motor. Refer GA drawing given in the catalogue.



B. General Specifications: Standard and Optional Features

<p>Range</p> <ul style="list-style-type: none"> • Series: 3 Phase Squirrel Cage Induction, Flame Proof Motors • Polarity: 2, 4, 6, 8 	Type	Frame	kW
	FLP Motors: Efficiency Values Complying to IE2 Class of IS 12615	80 to 355L	0.37 to 315
	FLP Motors: Efficiency Values Complying to IE3 Class of IS 12615	80 to 355L	0.37 to 315

Standard Features	Optional Features
Voltage: 415V	220 to 690V
Frequency: 50 Hz	60 Hz
IP55	IP56, IP65, IP66
B3 Mounting	B5, B35, V1
Ambient: 45°C	Any other on request
Duty: S1	S3 / S4 Duty: on request
TB Position: Top	TB Position: RHS from 112 to 315frame LHS from 160 to 315frame 355Frame : Top only
Cast Iron Construction: For all frames	
Shaft Material: EN8	EN24, EN57
Insulation: Class F	Insulation: Class H
IC411: Totally Enclosed Fan Cooled	
Sealed Bearing: upto 200 Frame Online Greasing Arrangement: 225 Frame and above	Online Greasing Arrangement: 180 to 200 Frame
Paint Shade: AAP 632	AAP Epoxy based RAL grade or Epoxy based IS:5 grade
Fan Cover: Mild Steel	
Gelcoat on Winding: For all frames	
	Space Heater: 90 Frame and above
Motor suitable for grid supply	Motors with Inverter Duty Suitability, offered with: 1. Combined testing for temperature class certification; test facility available 2. Motor fitted with PTC thermistor
Packing: Corrugated Boxes: Upto 100 Frame Wooden Packing Boxes: 112 Frame and above	Seaworthy/Export Packing Case
For standard bearings, kindly refer to the bearing chart	Insulated Bearing: 132 Frame and above (hybrid bearing till 225 Frame) Cylindrical Roller Bearing on DE Side: 160 Frame and above

Our other optional features

- Non standard shaft material, diameter and extension
- Double compression glands
- Auxiliary Terminal Box: 200 Frame and above
- Thermistor: 90 Frame and above
- Canopy, water flinger, non standard paint and paint shade
- High temperature grease
- Reduced and special grades of vibration as per IS 12075 can be provided on request

Note

- 1) Kindly confirm application wise requirement of cable sealing box and auxiliary terminal box with our nearest sales office.
- 2) For any other non standard feature, kindly contact our nearest sales office.
- 3) For enquiries of ATEX / IECEx certified motors, motors suitable for zone 21/22 kindly contact our nearest sales office.

FLAME PROOF MOTORS: Type Ex 'd'

C: Performance Data: Efficiency values complying to IE3 Efficiency Class of IS:12615

Voltage: 415V +/- 10%
Frequency: 50Hz +/- 5%
Combined Variation: +/- 10%

Ambient: 45°C
Duty: S1 (Continuous)
3000 rpm (2 Pole)

Insulation Class: Class F
Temperature Rise: Class B
Protection: IP55

Rated Output	Frame Size	IEC	Frame Size	Type Reference	Operating characteristics at rated output						With DOL starting			Rotor GD ²	Net Weight B3 constr.
					Rated Speed	Rated Current	Rated Torque	Power Factor			% Efficiency		Starting Current Ratio		
kW	HP	BBL	B3 construction	RPM	Amps.	kg-m	FL	3/4L	1/2L	FL	3/4L	1/2L	1/2L	kgm ²	kg
*0.37	0.5	80	MJ80	3J0802A300000	2830	0.85	0.13	0.82	0.74	0.62	73.8	73.8	70.0	0.0026	31
*0.55	0.75	80	MJ80	3J0802I300000	2830	1.23	0.19	0.8	0.73	0.6	78.1	77.1	74	0.0026	31
0.75	1.0	80	MJ80	3J0802B300000	2870	1.54	0.25	0.84	0.79	0.70	80.7	80.7	79.7	0.0034	32
1.1	1.5	80	MJ80	3J0802E300000	2850	2.28	0.38	0.81	0.76	0.65	82.7	82.7	80	0.0037	33
1.5	2.0	90S	MJ90	3J09L2B300000	2850	2.88	0.51	0.86	0.81	0.72	84.2	84.2	84.2	0.0066	45
2.2	3	90L	MJ90	3J09L2E300000	2850	4.14	0.75	0.86	0.8	0.71	85.9	85.9	85.5	0.0084	49
3.7	5.0	100L	MJ100	3J10L2B300000	2890	6.74	1.25	0.87	0.82	0.73	87.8	87.8	87.3	0.0158	61
5.5	7.5	132S	MJ132	3J13S2C300000	2935	9.53	1.83	0.9	0.87	0.81	89.2	89.2	87.5	0.0878	99
7.5	10.0	132S	MJ132	3J13S2H300000	2935	12.9	2.49	0.90	0.87	0.81	90.1	90.1	88.7	0.0936	109
9.3	12.5	160M	MJ160	3J16M2B300000	2950	16.59	3.07	0.86	0.83	0.76	90.7	90.3	88.7	0.150803	147
11	15.0	160M	MJ160	3J16M2E300000	2950	19.3	3.63	0.87	0.83	0.76	91.2	91.2	89.2	0.173	156
15	20	160M	MJ160	3J16M2H300000	2945	26.10	4.96	0.87	0.84	0.77	91.9	91.9	90	0.217435	164
18.5	25.0	160L	MJ160	3J16L2M300000	2945	31.3	6.12	0.89	0.86	0.79	92.4	92.4	90.8	0.258	181
22	30	180M	MJ180	3J18M2B300000	2950	37.52	7.26	0.88	0.84	0.78	92.7	92.7	91	0.336	277
30	40.0	200L	MJ200	3J20L2B300000	2955	50.8	9.89	0.88	0.86	0.80	93.3	93.3	91.8	0.59	323
37	50	200L	MJ200	3J20L2E300000	2955	62.43	12.20	0.88	0.86	0.8	93.7	93.7	92	0.651	351
45	60	225M	MJ225	3J22M2B300000	2965	75.7	14.8	0.88	0.86	0.82	94.0	94.0	93.0	1.19	458
55	75	250M	MJ250	3J25M2E300000	2970	91.17	18.04	0.89	0.86	0.8	94.3	94.3	93	1.68	570
75	100	280S	MJ280	3J28S2E300000	2970	121	24.6	0.91	0.89	0.86	94.7	94.7	92.7	2.9	740
90	120	280M	MJ280 S/M	3J28M2H300000	2970	144.83	29.52	0.91	0.89	0.86	95	95	93	3.42	765
110	150	315S	MJ315S/M	3J31S2E300000	2982	179	35.9	0.90	0.86	0.80	95.2	94.6	93.0	5.3	1042
132	180	315M	MJ315SMX	3J31M2H300000	2985	214.00	43.07	0.9	0.86	0.8	95.4	95.4	93.5	6.3	1174
150	200	315L	MJ315L	3J31L2K300000	2985	248	48.9	0.88	0.86	0.80	95.6	95.6	93.6	7.6	1361
160	215	315L	MJ315L	3J31L2M300000	2985	265.00	52.21	0.88	0.86	0.8	95.6	95.6	93.6	7.6	1361
180	240	315L	MJ315LX	3J31L2B300000	2983	294	58.8	0.89	0.87	0.81	95.7	95.7	95.1	8.3	1467
200	270	315L	MJ315LX	3J31L2P300000	2893	326.35	67.33	0.89	0.87	0.83	95.8	95.8	95.2	8.3	1467
225	300	355L	MJ355	3J35L2C300000	2987	355	73.4	0.92	0.89	0.84	95.8	95.8	93.8	16.2	2587
250	335	355L	MJ355	3J35L2E300000	2988	394.63	81.49	0.92	0.9	0.86	95.8	95.8	93.8	16.2	2587
280	375	355L	MJ355	3J35L2G300000	2987	442	91.3	0.92	0.90	0.86	95.8	95.8	93.8	18.9	2752

* These ratings are offered in higher frame size

Note: All performance values are subject to tolerance as per IS: 15999; Part 1

FLAME PROOF MOTORS: Type Ex 'd'

C: Performance Data: Efficiency values complying to IE3 Efficiency Class of IS:12615

Voltage: 415V +/- 10%
 Frequency: 50Hz +/- 5%
 Combined Variation: +/- 10%

Ambient: 45°C
 Duty: S1 (Continuous)
 1500 rpm (4 Pole)

Insulation Class: Class F
 Temperature Rise: Class B
 Protection: IP55

Rated Output		Frame Size	Frame Size	Type Reference	Rated Speed	Rated Current	Rated Torque	Operating characteristics at rated output				With DOL starting				Net Weight
kW	HP	IEC	BBL	B3 construction	RPM	Amps.	kg-m	Power Factor				Starting Current Ratio	Starting Torque Ratio	Pullout Torque Ratio	Rotor GD ²	B3 constr.
								FL	3/4L	1/2L	FL	3/4L	1/2L	% Efficiency	1/2L	kgm ²
*0.37	0.5	80	MJ80	3J08043300000	1405	0.90	0.26	0.74	0.69	0.58	77.3	77.3	70	77.3	0.0072	32
0.55	0.75	80	MJ80	3J08048300000	1415	1.18	0.38	0.80	0.70	0.56	80.8	80.8	79.8	80.8	0.0081	32
0.75	1	80	MJ80	3J0804E300000	1420	1.71	0.51	0.74	0.63	0.50	82.5	82.5	80.0	82.5	0.0094	33
0.75	1	90L	MJ90	3J09L423000000	1430	1.62	0.51	0.78	0.7	0.55	82.5	82.5	80.5	82.5	0.015	40
*1.1	1.5	90L	MJ90	3J09L483000000	1425	2.33	0.75	0.78	0.7	0.55	84.1	84.1	82.5	84.1	0.0121	40
1.5	2	90L	MJ90	3J09L4E3000000	1425	3.14	1.03	0.78	0.7	0.55	85.3	85.3	84.5	85.3	0.0149	43
2.2	3	100L	MJ100	3J10L483000000	1435	4.53	1.49	0.78	0.72	0.6	86.7	86.7	85.8	86.7	0.0245	58
3.7	5	112M	MJ112	3J11M4B3000000	1455	7.37	2.48	0.79	0.74	0.6	88.4	88.4	86.5	88.4	0.0588	69
5.5	7.5	132S	MJ132	3J13S4C3000000	1455	10.3	3.68	0.83	0.78	0.66	89.6	89.6	88.4	89.6	0.117	91
7.5	10	132M	MJ132	3J13M4H3000000	1455	13.9	5.02	0.83	0.78	0.66	90.4	90.4	89.4	90.4	0.157	106
9.3	12.5	160M	MJ160	3J16M4E3000000	1465	17.3	6.18	0.82	0.77	0.66	91	91	90.4	91	0.212	156
11	15	160M	MJ160	3J16M4H3000000	1465	20.4	7.31	0.82	0.77	0.66	91.4	91.4	90.8	91.4	0.235	167
15	20	160L	MJ160	3J16L4M3000000	1465	27.3	9.97	0.83	0.78	0.68	92.1	92.1	91.6	92.1	0.306	179
18.5	25	180M	MJ180	3J18M4B3000000	1470	33.1	12.3	0.84	0.80	0.70	92.6	92.6	91.5	92.6	0.555	274
22	30	180L	MJ180	3J18L4E3000000	1470	39.2	14.6	0.84	0.80	0.70	93.0	93.0	92.0	93.0	0.636	287
18.5	25	200L	MJ200	3J20L4A3000000	1470	31.9	12.3	0.87	0.82	0.73	92.6	92.6	90.6	92.6	0.86	305
30	40	200L	MJ200	3J20L4B3000000	1470	51.8	19.9	0.86	0.82	0.75	93.6	93.6	92.6	93.6	1.31	358
37	50	225S	MJ225	3J22S4B3000000	1480	65.3	24.4	0.84	0.80	0.71	93.9	93.9	93.4	93.9	1.79	445
45	60	225M	MJ225	3J22M4E3000000	1480	78.2	29.6	0.85	0.81	0.72	94.2	94.2	93.5	94.2	2.03	459
30	40	225M	MJ225	3J22M433000000	1475	51.3	19.8	0.87	0.85	0.77	93.6	93.6	91.3	93.6	1.6	430
37	50	250M	MJ250	3J25M4A3000000	1485	65.2	24.3	0.84	0.8	0.7	93.9	93.9	91.7	93.9	2.83	570
45	60	250M	MJ250	3J25M413000000	1485	79.1	29.5	0.84	0.8	0.7	94.2	94.2	92	94.2	2.83	570
55	75	250M	MJ250	3J25M4B3000000	1480	96.3	36.2	0.84	0.80	0.72	94.6	94.6	93.8	94.6	3.06	600
55	75	280S	MJ280	3J28S423000000	1485	95.2	36.1	0.85	0.81	0.72	94.6	94.6	92.1	94.6	5.53	705
75	100	280S	MJ280	3J28S4B3000000	1485	131	49.2	0.84	0.8	0.72	95	95	94.2	95	6.11	650
90	120	280M	MJ280	3J28M4H3000000	1487	155	59.0	0.85	0.82	0.74	95.2	95.2	94.5	95.2	7.14	730
110	150	315S	MJ315S/M	3J31S4G3000000	1488	189	72.0	0.85	0.82	0.74	95.4	95.4	93.9	95.4	11.9	1044
132	180	315M	MJ315SMX	3J31M4K3000000	1488	226	86.4	0.85	0.8	0.7	95.6	95.6	94.1	95.6	14.2	1167
160	215	315L	MJ315L	3J31L4P3000000	1490	277	105	0.84	0.80	0.72	95.8	95.8	94.5	94.5	16.1	1282
180	240	315L	MJ315LX	3J31L4T3000000	1491	311	118	0.84	0.8	0.72	95.9	95.9	94.6	94.6	18.3	1400
200	270	315L	MJ315LX	3J31L4W3000000	1491	345	131	0.84	0.80	0.72	96.0	96.0	95.0	96.0	22.5	1400
225	300	355L	MJ355	3J35L4B3000000	1490	375	147	0.87	0.83	0.72	96	96	95	96	27.5	2437
250	335	355L	MJ355	3J35L4E3000000	1492	416	163	0.87	0.83	0.72	96.0	96.0	95.0	96.0	27.5	2627
280	375	355L	MJ355	3J35L4C3000000	1492	466	183	0.87	0.83	0.72	96	96	95	96	32.02	2797

* These ratings are offered in higher frame size
 Note: All performance values are subject to tolerance as per IS: 15999; Part 1

FLAME PROOF MOTORS: Type Ex 'd'

C: Performance Data: Efficiency values complying to IE3 Efficiency Class of IS:12615

Voltage: 415V +/- 10%
 Frequency: 50Hz +/- 5%
 Combined Variation: +/- 10%

Ambient: 45°C
 Duty: S1 (Continuous)
 1000 rpm (6 Pole)

Insulation Class: Class F
 Temperature Rise: Class B
 Protection: IP55

Rated Output		Frame Size	Frame Size	Type Reference	Rated Speed	Rated Current	Rated Torque	Operating characteristics at rated output				With DOL starting			Net Weight				
kW	HP	IEC	BBL	B3 construction	RPM	Amps.	kg-m	Power Factor	% Efficiency			Starting Current to Rated Current Ratio	Starting Torque to Rated Torque Ratio	Pullout Torque to Rated Torque Ratio	Rotor GD ²	B3 constr.			
								FL	3/4L	1/2L	FL	3/4L	1/2L				kg		
0.37	0.5	80	MJ80	3J0806B300000	910	0.96	0.40	0.73	0.62	0.53	0.73	0.62	0.53	72.5	4.0	2.2	2.5	0.0073	29
0.55	0.75	80	MJ80	3J0806E300000	920	1.38	0.58	0.72	0.64	0.52	0.72	0.64	0.52	76.0	4.0	2.3	2.6	0.0101	32
0.55	0.75	90L	MJ90	3J09L63300000	910	1.38	0.59	0.72	0.62	0.5	0.72	0.62	0.5	74	4	1.8	2.3	0.0122	40
*0.75	1	90L	MJ90	3J09L683000000	925	1.84	0.79	0.72	0.62	0.52	0.72	0.62	0.52	78.6	4	2.1	2.5	0.0143	39
1.1	1.5	90L	MJ90	3J09L6E300000	920	2.62	1.16	0.72	0.62	0.52	0.72	0.62	0.52	80	4	2	2.5	0.0181	43
1.5	2	100L	MJ100	3J10L6B300000	935	3.51	1.56	0.72	0.62	0.54	0.72	0.62	0.54	81	4.5	2.3	2.5	0.0275	56
2.2	3	112M	MJ112	3J11M6B300000	960	4.84	2.23	0.75	0.68	0.55	0.75	0.68	0.55	81	6	2.3	2.5	0.0691	68
3.7	5	132S	MJ132	3J13S6C300000	960	7.83	3.75	0.76	0.7	0.58	0.76	0.7	0.58	86	5.5	2.2	2.6	0.121	90
5.5	7.5	132M	MJ132	3J13M6H300000	965	11.3	5.55	0.77	0.7	0.6	0.77	0.7	0.6	88	5.5	2.2	2.6	0.18	107
7.5	10	160M	MJ160	3J16M6B300000	970	15.2	7.53	0.77	0.72	0.61	0.77	0.72	0.61	88.5	6	2	2.6	0.275	156
9.3	12.5	160L	MJ160	3J16L6E300000	970	18.7	9.34	0.77	0.72	0.61	0.77	0.72	0.61	89	6	2	2.6	0.332	167
11	15	160L	MJ160	3J16L6H300000	970	22.0	11.0	0.77	0.72	0.61	0.77	0.72	0.61	89.2	6	2	2.6	0.39	178
15	20	180L	MJ180	3J18L6B300000	977	27.6	15.0	0.83	0.78	0.72	0.83	0.78	0.72	91.2	5.5	2.5	3.0	0.888	284
15	20	200L	MJ200	3J20L63300000	970	28.6	15.1	0.8	0.75	0.62	0.8	0.75	0.62	89.2	5.5	2.6	2.3	1.2	290
18.5	25	200L	MJ200	3J20L6B300000	980	34.2	18.4	0.82	0.79	0.70	0.82	0.79	0.70	91.0	6.0	2.7	3.2	1.23	295
22	30	200L	MJ200	3J20L6E300000	980	40.5	21.9	0.82	0.80	0.70	0.82	0.80	0.70	91.2	6.0	2.7	3.2	1.47	324
22	30	225M	MJ225	3J22M62300000	975	38.2	22.0	0.87	0.84	0.76	0.87	0.84	0.76	92.2	6.5	2.3	2.2	2.1	430
30	40	225M	MJ225	3J22M6B300000	984	51.1	29.7	0.88	0.84	0.77	0.88	0.84	0.77	92.9	6.5	3.0	3.5	2.85	450
30	40	250M	MJ250	3J25M60300000	980	51.6	29.8	0.87	0.85	0.78	0.87	0.85	0.78	91.8	7	2.75	3.1	3.51	560
37	50	250M	MJ250	3J25M6B300000	985	63.4	36.6	0.87	0.85	0.77	0.87	0.85	0.77	93.3	7	2.8	3	3.41	573
45	60	280S	MJ280	3J28S6B300000	984	79.5	44.5	0.84	0.8	0.72	0.84	0.8	0.72	93	6	2.4	2.9	5.11	650
55	75	280M	MJ280	3J28M6E300000	985	95.7	54.4	0.85	0.81	0.72	0.85	0.81	0.72	94.1	6	2.5	3	6.82	736
75	100	315S	MJ315S/M	3J31S6B300000	992	130	73.6	0.85	0.82	0.72	0.85	0.82	0.72	94.6	6.0	2.5	3.0	11.9	950
90	120	315M	MJ315S/M	3J31M6E300000	992	155	88.4	0.85	0.82	0.72	0.85	0.82	0.72	94.9	6.0	2.5	3.0	13.6	1015
110	150	315M	MJ315S/M	3J31M6H300000	992	189	108	0.85	0.82	0.72	0.85	0.82	0.72	95.1	6.0	2.5	3.0	16.5	1127
132	180	315L	MJ315L	3J31L6M300000	992	229	130	0.84	0.80	0.72	0.84	0.80	0.72	95.4	6.0	2.5	3.0	19.6	1295
160	215	315L	MJ315LX	3J31L6P300000	992	277	157	0.84	0.81	0.75	0.84	0.81	0.75	95.6	6.0	2.2	2.4	23.2	1449
180	240	355L	MJ355	3J35L6C300000	990	319	177	0.82	0.78	0.66	0.82	0.78	0.66	94.0	6.0	2.0	2.5	28.3	2437
200	270	355L	MJ355	3J35L6E300000	991	346	197	0.84	0.80	0.70	0.84	0.80	0.70	95.8	6.0	2.0	2.5	35.1	2612
250	335	355L	MJ355	3J35L64300000	991	432	246	0.84	0.80	0.70	0.84	0.80	0.70	94.1	6.0	2.0	2.5	40.2	2762

* These ratings are offered in higher frame size
 Note: All performance values are subject to tolerance as per IS: 15999; Part 1

FLAME PROOF MOTORS: Type Ex 'd'

C: Performance Data: Efficiency values complying to IE3 Efficiency Class of IS:12615

Voltage: 415V +/- 10%
 Frequency: 50Hz +/- 5%
 Combined Variation: +/- 10%

Ambient: 45°C
 Duty: S1 (Continuous)
 750 rpm (8 Pole)

Insulation Class: Class F
 Temperature Rise: Class B
 Protection: IP55

Rated Output		Frame Size	Frame Size	Type Reference	Operating characteristics at rated output			With DOL starting			Net Weight							
kW	HP	IEC	BBL	B3 construction	Rated Speed	Rated Current	Rated Torque	% Efficiency			B3 constr.							
					RPM	Amps.	kg-m	FL	3/4L	1/2L	FL	3/4L	1/2L	Starting Current to Rated Current Ratio	Starting Torque to Rated Torque Ratio	Pullout Torque to Rated Torque Ratio	Rotor GD ²	kg
0.18	0.25	80	MJ80	3J08081300000	675	0.78	0.26	0.55	0.48	0.40	58.7	58.7	52.0	3	1.8	2.2	0.0054	27
0.25	0.33	80	MJ80	3J08083300000	675	0.94	0.36	0.58	0.48	0.40	64.1	64.1	58.0	3.0	1.8	2.2	0.0078	29
0.37	0.5	90L	MJ90	3J09L853000000	700	1.09	0.51	0.68	0.58	0.45	69.3	69.3	65	3.5	1.8	2	0.013	37
0.55	0.75	90L	MJ90	3J09L863000000	690	1.54	0.78	0.68	0.58	0.45	73	73	68	3.5	1.8	2	0.017	39
0.75	1	100L	MJ100	3J10L833000000	695	1.99	1.05	0.7	0.6	0.5	75	75	73	3.8	1.9	2.3	0.027	53
1.1	1.5	100L	MJ100	3J10L853000000	695	2.81	1.54	0.7	0.6	0.5	77.7	77.7	75	3.8	1.9	2.3	0.034	56
1.5	2	112M	MJ112	3J11M833000000	700	3.64	2.09	0.72	0.64	0.52	79.7	79.7	78	3.8	1.7	2.2	0.059	62
2.2	3	132S	MJ132	3J13S883000000	710	5.05	3.02	0.74	0.66	0.55	81.9	81.9	80	3.8	1.7	2.2	0.091	81
3.7	5	160M	MJ160	3J16M823000000	715	8.12	5.04	0.75	0.7	0.58	84.5	84.5	83	4.8	1.7	2.2	0.219	139
5.5	7.5	160M	MJ160	3J16M843000000	715	11.8	7.49	0.75	0.7	0.58	86.2	86.2	85	4.8	1.8	2.3	0.35	160
7.5	10	160L	MJ160	3J16L883000000	715	15.9	10.2	0.75	0.7	0.58	87.3	87.3	86	4.8	1.8	2.3	0.418	170
9.3	12.5	180M	MJ180	3J18M873000000	725	19.3	12.5	0.76	0.70	0.60	88.1	88.1	87.0	5.5	2.0	2.2	0.817	274
11	15	180L	MJ180	3J18L893000000	725	22.7	14.8	0.76	0.70	0.60	88.6	88.6	87.5	5.5	2.0	2.2	0.907	284
15	20	200L	MJ200	3J20L853000000	725	28.4	20.2	0.82	0.77	0.65	89.6	89.6	88.6	6.0	2.3	2.5	1.45	318
18.5	25	225S	MJ225	3J22S823000000	725	34.8	24.9	0.82	0.80	0.72	90.1	90.1	89.1	5.5	2.0	2.2	2.11	383
22	30	225M	MJ225	3J22M833000000	725	41.2	29.6	0.82	0.80	0.72	90.6	90.6	89.6	5.5	2.0	2.2	2.41	405
30	40	250M	MJ250	3J25M813000000	730	55.7	40.0	0.82	0.80	0.72	91.3	91.3	91.0	5.5	2.0	2.2	3.28	560
37	50	280S	MJ280	3J28S823000000	730	71.9	49.4	0.78	0.74	0.65	91.8	91.8	91.0	5.5	2.0	2.2	6.18	725
45	60	280M	MJ280	3J28M853000000	738	89.3	59.4	0.76	0.72	0.60	92.2	92.2	91.5	5.5	2.0	2.2	7.25	775
55	75	315S	MJ315S/M	3J31S813000000	740	110	72.4	0.75	0.7	0.60	92.5	92.5	92	5.5	1.8	2	11.4	920
75	100	315M	MJ315S/M	3J31M833000000	739	151	98.8	0.74	0.7	0.62	93.1	93.1	92.5	5.5	1.8	2	12.6	971
90	120	315M	MJ315S/M	3J31M853000000	741	176	118	0.76	0.72	0.64	93.4	93.4	93	5.5	1.8	2	15.9	1096
110	150	315L	MJ315L	3J31L873000000	742	221	144	0.74	0.69	0.58	93.7	93.7	93	5.5	2.0	2.2	18.9	1263
125	170	315L	MJ315L	3J31L8A3000000	742	244	164	0.76	0.7	0.60	93.9	93.9	93	5.5	2.0	2.2	22.9	1415
132	180	315L	MJ315L	3J31L893000000	742	257	173	0.76	0.72	0.62	94	94	93	5.5	2.0	2.2	22.9	1415
160	215	355L	MJ355L	3J35L883000000	742	303	210	0.78	0.7	0.60	94.3	94.3	92.5	5.5	1.8	2.2	35.1	2612
180	240	355L	MJ355L	3J35L8C3000000	742	340	236	0.78	0.70	0.60	94.50	94.50	92.50	5.5	1.8	2.2	42.50	2827

* These ratings are offered in higher frame size

Note: All performance values are subject to tolerance as per IS: 15999; Part 1

FLAME PROOF MOTORS: Type Ex 'd'

D: Dimensional Drawing: Efficiency Values Complying to IE3 Efficiency Class of IS 12615 Foot Mounted IMB3/IM1001 Motors

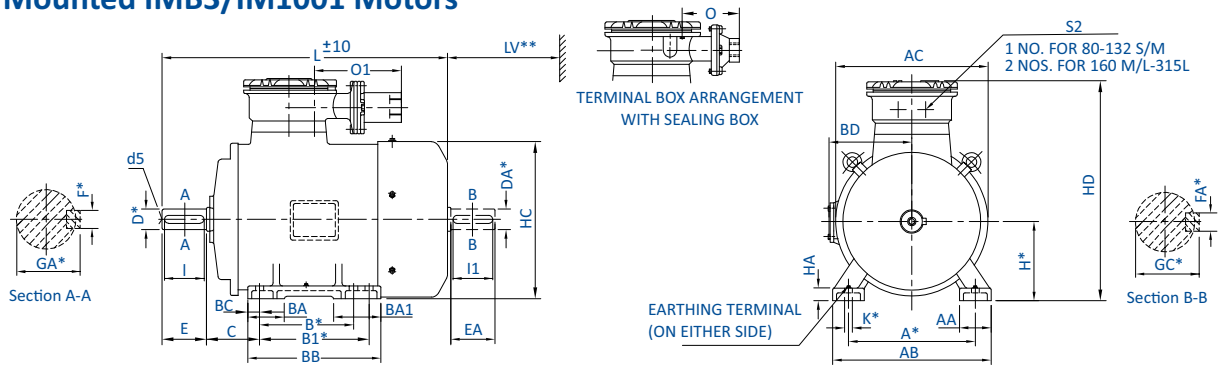

IEC Fr. Size	BBL Fr. Size	Pole	FIXING				GENERAL										TERMINAL BOX					SHAFT									
			A*	B*	B1*	C	H*	K*	AB	BB	AA	BA	BA1	BC	HA	HC	HD	L	AC	LV**	BD	O	O1	S2	D*	E	F*	GA*	I	d5	
80	MJ80	2, 4, 6 & 8	125	100	—	50	80	10	153	126	32	36	—	16	10	162	296	330	164	30	—	214	135	M20x1.5P	19	40	6	21.5	35	M6	
	MJ80L	2(1.1kW) 4(0.55kW) 6(0.55kW)																352													
90L	MJ90	2, 4, 6 & 8	140	125	—	56	90	10	180	160	50	40	—	16	13	177	336	382	174	35	—	217	141	M25x1.5P	24	50	8	27	45	M8	
	MJ90L	2(2.2kW) 4(1.5kW) 6(1.1kW)																418													
100L	MJ100L	2, 4	160	140	—	63	100	12	200	176	54	45	—	21	14	198	358	465	195	40	—	207	131	M25x1.5P	28	60	8	31	55	M10	
	MJ100	6, 8																435													
112M	MJ112	2, 8	190	140	—	70	112	12	230	176	50	55	—	21	15	222	374	456	220	45	—	200	124	M25x1.5P	28	60	8	31	55	M10	
	MJ112M	4, 6																481													
132S/M	MJ132	2, 4, 6 & 8	216	140	178	89	132	12	256	218	50	53	77	23	17	262	408	551	260	50	—	175	100	M25x1.5P	38	80	10	41	70	M12	
	MJ132S/M	2(7.5kW) 4(7.5kW) 6(5.5kW)																602													
160M/L	MJ160	2	254	210	254	108	160	15	314	294	60	70	115	23	20	317	472	704	314	60	—	252	151	M25x1.5P	42	110	12	45	105	M16	
	MJ160M/L	4, 6 & 8																694													
		2(18.5kW) 6(11kW)																734													
180M/L	MJ180M/L	2, 4, 6 & 8	279	241	279	121	180	15	339	426	80	112	212	55	26	357	515	850	354	70	—	270	166	M25x1.5P	48	110	14	51.5	100	M16	
200L	MJ200L	2, 4	318	305	—	133	200	19	398	355	85	85	—	28	32	397	556	805	394	80	—	237	113	M25x1.5P	55	110	16	59	100	M20	
		6, 8																771													
		2(37kW) 4(30kW) 6(22kW) 8(15kW)																870													
																		840													
225S/M	MJ225S/M	2	356	286	311	149	225	19	436	361	85	85	110	28	34	447	651	882	444	90	—	308	264	M40x1.5P	55	110	16	59	100	M20	
	MJ225	4, 6																912													
250M	MJ250M	2	406	349	—	168	250	24	506	425	100	115	—	49	42	495	688	994	489	100	—	287	242	M40x1.5P	60	140	18	64	130	M20	
		MJ250																4, 6													915
		MJ280																2													1010
280S/M	MJ280S/M	2(90kW)	457	368	419	190	280	24	540	490	110	110	149	41	42	552	755	1100	544	115	—	252	207	M40x1.5P	60	140	18	69	130	M20	
	MJ280	4, 6 & 8																1010													
315S/M	MJ315S/M	2	508	406	457	216	315	28	625	540	120	115	155	46	49	617	850	1178	606	130	758	256	225	M50x1.5P	65	140	18	69	130	M20	
	MJ315S/MX	2(132kW)																1270													
	MJ315S/M	4, 6 & 8																1163													
	MJ315S/MX	4(132kW)																1255													
315L	MJ315L	2	508	508	—	216	315	28	625	593	120	115	115	46	45	617	850	1343	606	145	758	276	225	M50x1.5P	65	140	18	69	130	M20	
	MJ315LX	2(180kW,200kW)																1435													
	MJ315L	4, 6 & 8																1328													
	MJ315LX	4(180kW,200kW)																1420													

Tolerances on Dimensions with*

Dimension	Tolerance	Specification	
A, B	±0.75	IS : 1231	
H	-0.5		UPTO 280
	-1.0		OVER 280
K	+0.360		10∅
	+0.430	12, 15∅	
	+0.520	19, 24, 28∅	

Dimension	Tolerance	Specification
D, DA	j6	19, 24, 28∅
	k6	38, 42, 48∅
	m6	55, 60, 65, 75, 80, 90∅
GA, GC, F, FA		IS : 2048

□ Key / key way fit: h9 / N9.

□ Double shaft extension can be provided with shaft dimension identical to D.E. shaft.

Note: For non standard motors, dimensions may change. Please contact our nearest sales office for details

** Minimum distance for efficient cooling of motor to be maintained by user.

All Dimensions are in mm unless otherwise specified.

CAT-D-80315-3-1

FLAME PROOF MOTORS: Type Ex 'd'

D: Dimensional Drawing: Efficiency Values Complying to IE3 Efficiency Class of IS 12615 Flange Mounted IMB5/IM3001 Motors

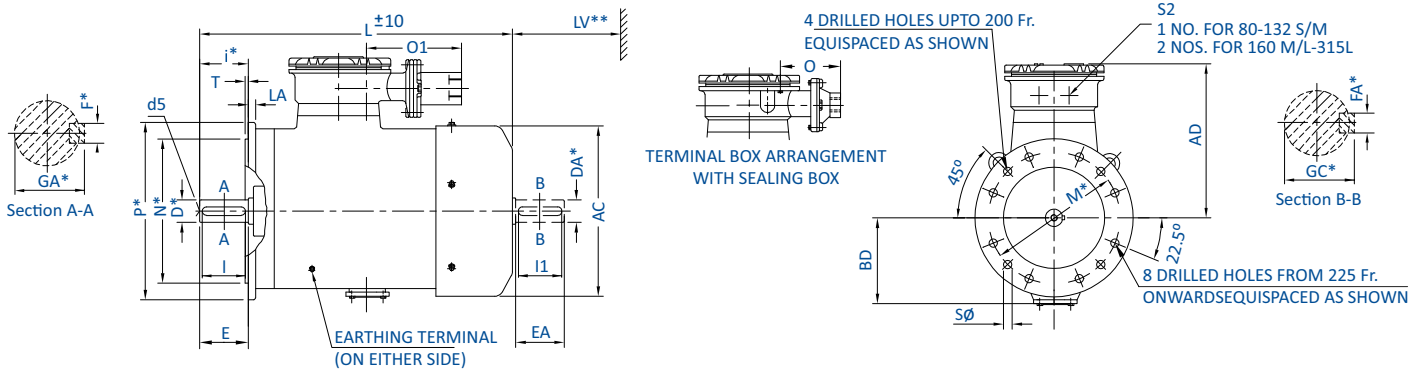

IEC Fr. Size	BBL Fr. Size	Pole	FIXING				GENERAL						TERMINAL BOX				SHAFT						
			P*	N*	M*	i*	S	T	LA	AC	L	AD	LV**	BD	O	O1	S2	D DA*	E EA	F FA*	GA* GC*	I I1	d5
80	MJ80	2, 4, 6 & 8	200	130	165	40	12	3.5	11	164	330	216	30	—	214	135	M20x1.5P	19	40	6	21.5	35	M6
	MJ80L	2(1.1kW) 4(0.55kW) 6(0.55kW)									352												
90L	MJ90	2, 4, 6 & 8	200	130	165	50	12	3.5	11	174	382	246	35	—	217	141	M25x1.5P	24	50	8	27	45	M8
	MJ90L	2(2.2kW) 4(1.5kW) 6(1.1kW)									418												
100L	MJ100L	2, 4	250	180	215	60	15	4	12	195	465	258	40	—	207	131	M25x1.5P	28	60	8	31	55	M10
	MJ100	6, 8									435												
112M	MJ112	2, 8	250	180	215	60	15	4	12	220	456	262	45	—	200	124	M25x1.5P	28	60	8	31	55	M10
	MJ112M	4, 6									481												
132S/M	MJ132	2, 4, 6 & 8	300	230	265	80	15	4	13	260	551	290	50	—	175	100	M25x1.5P	38	80	10	41	70	M12
	MJ132S/M	2(7.5kW) 4(7.5kW) 6(5.5kW)									602												
160M/L	MJ160	2	350	250	300	110	19	5	13	314	704	312	60	—	252	151	M25x1.5P	42	110	12	45	105	M16
		4, 6 & 8									694												
		2(18.5kW) 6(11kW)									734												
180M/L	MJ180M/L	2, 4, 6 & 8	350	250	300	110	19	5	16	354	875	335	70	—	270	166	M25x1.5P	48	110	14	51.5	100	M16
200L	MJ200	2, 4	400	300	350	110	19	5	15	394	826	356	80	—	237	133	M25x1.5P	55	110	16	59	100	M20
		6, 8									792												
		2(37kW) 4(30kW)									891												
		6(22kW) 8(15kW)									861												
225S/M	MJ225S/M	2	450	350	400	140	19	5	16	444	882	426	90	—	308	264	M40x1.5P	55	110	16	59	100	M20
		4, 6									912												
250M	MJ250	8	550	450	500	140	19	5	18	489	836	438	100	—	287	242	M40x1.5P	60	140	18	64	130	M20
		2									994												
		4, 6									915												
		8									1010												
280S/M	MJ280S/M	2(90kW)	550	450	500	140	19	5	18	544	1100	475	115	—	252	207	M40x1.5P	65	140	18	69	130	M20
		4, 6 & 8									1010												
		2									1178												
315S/M	MJ315S/M	2	660	550	600	140	24	6	23	610	1178	535	130	326	276	225	M50x1.5P	65	140	18	69	130	M20
		2(132kW)									1270												
		4, 6 & 8									1255												
		4(132kW)									1163												
315L	MJ315L	2	660	550	600	140	24	6	23	610	1343	535	145	326	276	225	M50x1.5P	65	140	18	69	130	M20
		2(180kW,200kW)									1435												
		4, 6 & 8									1328												
		4(180kW,200kW)									1420												

Tolerances on Dimensions with*

Dimension	Tolerance	Specification
N	j6	UPTO 450
	js6	OVER 450
M	±0.3	UPTO 265
	±0.5	OVER 265
i	±1	UPTO 85
	±1.5	OVER 85

IS : 2223

Dimension	Tolerance	Specification
D, DA	j6	19, 24, 28Ø
	k6	38, 42, 48Ø
GA, GC, F, FA	m6	55, 60, 65, 75, 80, 90Ø

IS : 1231
IS : 2048

** Minimum distance for efficient cooling of motor to be maintained by user.

Note: For motor in frame 180M/L & 200L with B3/B5 Mounting, kindly refer to our nearest sales office. For non standard motors, dimensions may change. Please contact our nearest sales office for details.

- Separate space. heater T. Box will be provided as a std. feature in case of 315 S/M/L frames.
- Double shaft extension can be provided with shaft dimension identical to D.E. shaft.
- 8 Nos. Fixing Holes from 225 S/M frame onwards
- Key / key way fit: h9 / N9.

All Dimensions are in mm unless otherwise specified.

CAT-D-80315-5-1

FLAME PROOF MOTORS: Type Ex 'd'

D. Dimensional Drawing: Efficiency Values Complying to IE3 Efficiency Class of IS 12615 Flange Mounted IMV1/IM3011 Motors

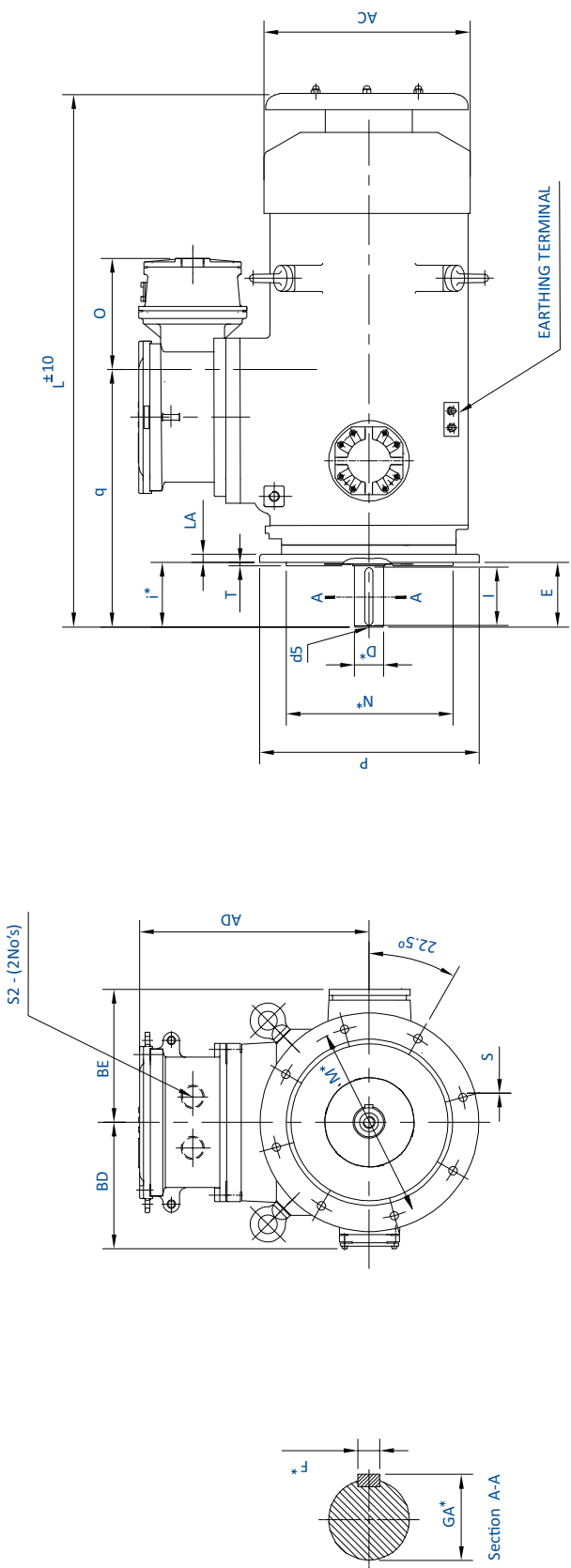

BBL Fr. Size	IEC Fr. Size	Pole	P*	FIXING				GENERAL				TERMINAL BOX				SHAFT							
				N*	M*	i*	S	T	LA	AC	L	AD	O	BD	BE	q	S2	D	E	F*	GA*	I	d5
M1355	3555/M/L	2	800	680	740	210	24	6	28	720	1869	791	364	420	420	904	M63X1.5P	75	170	20	79.5	160	M20
		4, 6 & 8																					

Tolerances on Dimensions with*

Dimension	Tolerance	Specification
N	js6	
M	± 1.0	IS : 2223
i	± 1.5	

Dimension	Tolerance	Specification
D	m6	IS:1231/IEC:60072-1
GA, F,		IS:2048
d5(centering)		IS:2540

- Key / key way fit: h9 / N9.
- Double shaft extension can be provided with shaft dimension identical to D.E. shaft.
- ** Minimum distance for efficient cooling of motor to be maintained by user.
- Note** For non standard motors, dimensions may change. Please contact our nearest sales office for details.
- All Dimensions are in mm unless otherwise specified.



ISO 9001 : 2015



ISO 45001:2018



ISO 14001 : 2015



Super Premium Energy Efficient
SynchroVERT™ IE4 Motor:
Winner of CII's Most Innovative
Energy Saving Product 2016



Ultra Premium Energy Efficient
IE5 Motor:
Winner of CII's Most Innovative
Energy Saving Product 2018

LV MOTORS PRODUCT RANGE

Motors conform to relevant Indian Standards IS/IEC 60034 series

Voltage: 415V +/- 10%, Frequency: 50 Hz +/- 5%, Combined Variation: +/- 10%

Motor Type	Frame	Power (kW)	Polarity		Standard Technical Specifications
IE2 Motors	56 to 355	0.12 to 355	2, 4, 6, 8		<ul style="list-style-type: none"> Ambient: 50° C Ambient for DCCA: 40° C Inverter Grade Winding: For IE3 and DCCA Duty: S1 RTD & BTD: For DCCA motors Mounting: B3, B5, B35, V1, B14 upto 132 Frame
IE3 Motors	56 to 355	0.12 to 355	2, 4, 6, 8		
Large LT Motors (DCCA)	355 to 450	250 to 1250	2, 4, 6, 8		
IE4 Motors	112 to 225	1.5 to 45	4		<ul style="list-style-type: none"> Ambient: 50° C Inverter Duty Winding Duty: S1 VPI: With Class H solvent less Resin Mounting: B3, B5, B35, V1
Standard Flame Proof Ex'd' Motors	80 to 315	0.37 to 200	2, 4, 6, 8		<ul style="list-style-type: none"> Ambient: 45° C Inverter Grade Winding: For IE3 Motors Duty: S1 Mounting: B3, B5, B35, V1
IE2 Flame Proof Ex'd' Motors	80 to 355	0.37 to 315	2, 4, 6, 8		
IE3 Flame Proof Ex'd' Motors	80 to 355	0.37 to 315	2, 4, 6, 8		
IE2 Increased Safety Ex ec Motors	63 to 355	0.12 to 355	2, 4, 6, 8		<ul style="list-style-type: none"> Ambient: 50° C Duty: S1 Mounting: B3, B5, B35, V1 (B14 upto 132 Frame)
IE3 Increased Safety Ex ec Motors	63 to 355	0.12 to 355	2, 4, 6, 8		
Crane & Hoist Duty Motors	71 to 355	0.37 to 400	4, 6, 8		<ul style="list-style-type: none"> Ambient: 45° C Duty: S4 Offered in DOL & Converter Fed Supply Mounting: B3, B5, B35, V1 (B14 upto 132 Frame)
Brake Motors (With Integral DC Brake)	71 to 132	0.25 to 9.3	2, 4, 6, 8		<ul style="list-style-type: none"> Ambient: 50° C Duty: S1 Mounting: B3, B5, B35 Integral DC Brake
Brake Motors (With External Mounted Brake)	71 to 200	0.37 to 22	2, 4, 6, 8		<ul style="list-style-type: none"> Ambient: 50° C Duty: S1 Mounting: B3, B5, B35 External Mounted DC Brake/Arrangement
Slip Ring Motors	100 to 160	1.1 to 10	4, 6		<ul style="list-style-type: none"> Ambient: 45° C Duty: S3, S4, S5 Mounting: B3
Textile Motors	100 to 160	1.1 to 15	4, 6, 8		<ul style="list-style-type: none"> Ambient: 50° C Duty: S1 Mounting: B3, B5, B35
Cane Unloader Motors	160 to 225	11 to 30	6		<ul style="list-style-type: none"> Ambient: 45° C Start/Stop per Hour: upto 900 Duty: S5, 50% CDF Thermostat Mounting: B3, B5, B35 Forced Cooling Shaft Material: En24

**Insulation: Class 'F' with temperature rise limited to Class 'B', Rotation: Bi-directional
Cooling: IC411, Degree of Protection: IP55, Altitude: Upto 1000m above MSL**

Optional Features		Applications
<ul style="list-style-type: none"> • Non Standard Voltage: upto 690V • Higher Polarity on request • Insulation: Class H • Space Heater: 90 Frame onwards • RTD & BTD: 250 Frame onwards • PTC Thermistor: 80 to 355L • Shaft Material: EN24* • Enclosure: IP56 / 65 / 66 • Forced Cooling: 132 to 450 Frame • Roller Bearing: 160 Frame onwards 	<ul style="list-style-type: none"> • High Temperature Grease: Suitable up to 200° C • SS Hardware • Non standard shaft diameter/extension* • Non Standard Paint • Provision for Encoder Mounting • Low Vibration as per IS or IEC • Insulated Bearing: 132 Frame onwards • SPM Nipples Provision: Frame 250 onwards 	<p>Pump, Fan, Compressor, Packing Machinery, Coiler/De-coiler, Agro Equipment, Food Processing Equipment, Paper Machinery, Agitator, Dairy Equipment, Machine Tool, Air Conditioning, Material Handling, Plastic Machinery, Textile Machinery, Cooling Tower, Crusher, Material Handling</p>
<ul style="list-style-type: none"> • Insulation: Class H • Space Heater: 90 Frame onwards • PTC Thermistor: 80 to 225 Frame • Shaft Material: EN24* • Enclosure: IP56 / 65 / 66 • Roller Bearing: 160 Frame onwards 	<ul style="list-style-type: none"> • Non standard shaft diameter/extension* • Non Standard Paint • Provision for Encoder Mounting • Low Vibration as per IS or IEC 	<p>Fans, HVAC, Pumps, Textiles, Hydraulic Press</p>
<ul style="list-style-type: none"> • Non Standard Voltage: 220 to 690V • Intermittent Duty S3, S4: In 4, 6, 8 Pole* • Insulation: Class H • PTC Thermistor: 80 to 315 L • Space Heater: 90 Frame onwards • Roller Bearing: 160 Frame onwards • Shaft Material: EN24* • Enclosure: IP56 / 65 / 66 	<ul style="list-style-type: none"> • Insulated Bearing: 132 Frame onwards • Non standard shaft diameter/extension* • Motors for inverter duty application ; offered with <ul style="list-style-type: none"> • Combined testing of motor and VFD or • Motors fitted with PTC Thermistor • Test facility available for combined Testing with VFD • Non Standard Paint • Low Vibration as per IS or IEC 	<p>Pump, Fan, Compressor, Material Handling, Agitator, LPG Bottling Plant, Pharma Machinery, Chemical Plant Machinery, Machinery for Mines</p>
<ul style="list-style-type: none"> • Insulation: Class H • Shaft Material: EN24* • Enclosure: IP56 / 65 / 66 • Roller Bearing: 160 Frame onwards 	<ul style="list-style-type: none"> • Insulated Bearing: 132 Frame onwards • Non standard shaft diameter/extension* • Motors for inverter duty application with combined testing of motor and VFD for temperature class certification • Test facility available for combined testing with VFD • Non Standard Paint • Low Vibration as per IS or IEC 	<p>Pump, Fan, Compressor, Material Handling, Agitator, Pharma Machinery</p>
<ul style="list-style-type: none"> • Duty: S2, S3 and S5 • Non Standard Voltage: 380 to 460V • Insulation: Class H • Space Heater: 90 Frame onwards • BTD: 250 Frame and above • PTC Thermistor: 80 to 355 L • Roller Bearing: 160 Frame onwards • Shaft Material: EN24* • Enclosure: IP56 / 65 / 66 	<ul style="list-style-type: none"> • Motors for Inverter Duty • Insulated Bearing: 132 Frame onwards • Non standard shaft diameter/extension* • Non Standard Paint • Low Vibration as per IS or IEC 	<p>Crane, Hoist, Lift, Material Handling, Car Stacker, Door Opening</p>
<ul style="list-style-type: none"> • Duty: S2 and above • Non Standard Voltage: upto 460V • Motors for Inverter Duty • Manual Release Arrangement: For 90 to 132 Frame 	<ul style="list-style-type: none"> • Non standard shaft diameter/extension* • Non Standard Paint 	<p>Crane, Hoist, Material Handling, Textile, Pharma to name a few</p>
<ul style="list-style-type: none"> • Duty: S2 and above • Non Standard Voltage: upto 460V • Motors for Inverter Duty • Manual Release Arrangement 	<ul style="list-style-type: none"> • Double Shaft Extension for Brake Arrangement • Non Standard Paint 	<p>Crane, Hoist, Material Handling, Textile, Pharma to name a few</p>
<ul style="list-style-type: none"> • Mounting: B35 • Non standard shaft diameter and extension* 	<ul style="list-style-type: none"> • Non Standard Paint 	<p>Crane, Hoist, Lift, Material Handling</p>
<ul style="list-style-type: none"> • Non Standard Voltage: upto 500V • Insulation: Class H 	<ul style="list-style-type: none"> • Motors for Inverter Duty • Non Standard Paint • Low Vibration as per IS 	<p>Ginning, Textile Machinery</p>
<ul style="list-style-type: none"> • Insulation: Class H • PTC Thermistor 	<ul style="list-style-type: none"> • Insulated Bearing: 132 Frame onwards • Non Standard Paint 	<p>Cane Loading-Unloading Machine</p>

ENABLING PRODUCTIVITY, PRECISION & ENERGY EFFICIENCY

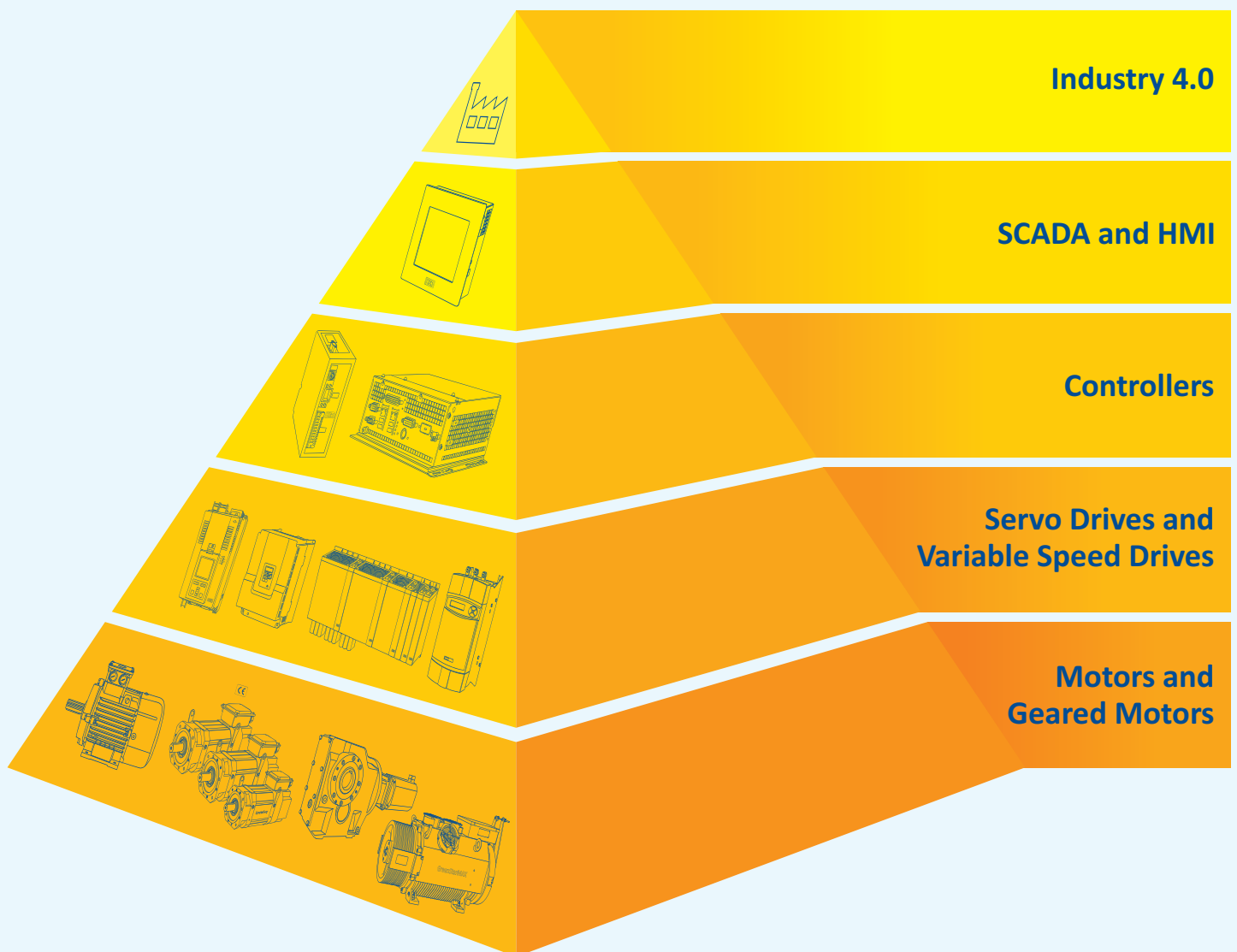

Bharat Bijlee's Industrial Systems product portfolio caters to a spectrum of applications and spans the machine automation pyramid.

ALL INDIA SERVICE NETWORK

- Regional Offices
- 🔥 Works
- Authorised Service Centre: Motors
- ✕ Service Centre: Servo Motors



REGIONAL OFFICES

- Mumbai** +91 22 61457200
- Pune** +91 7410011271 / 72
- Ahmedabad** +91 79 66049200
- New Delhi** +91 11 25816931 / 32 / 33
- Indore** +91 731 2524474 / 2514486
- Ludhiana** +91 161 2775692 / 93
- Jaipur** +91 141 2377223
- Kolkata** +91 33 24432383 / 2467 / 40623076 / 77
- Bengaluru** +91 80 25592646 / 2137 / 2681
- Chennai** +91 44 2815 4793 / 94
- Secunderabad** +91 40 27801791 / 27814512
- Coimbatore** +91 422 4204314

BB ServiceLINE®
 Customer Service Helpdesk for Industrial Systems
 +91 22 - 2763 7290
 +91 22 - 2763 7490
 serviceline@bharatbijlee.com

For any enquiries please write to
motorlvsales@bharatbijlee.com



Scan to download our
 IES3 FLP Motors catalogue



REGISTERED OFFICE
 Electric Mansion, 6th Floor,
 Appasaheb Marathe Marg,
 Prabhadevi, Mumbai 400 025
 T: +91 22 4614 1414
 E: info@bharatbijlee.com
 CIN: L31300MH1946PLC005017

WORKS
 No. 2, MIDC Thane-Belapur Road, Airoli,
 Navi Mumbai 400 708
 T: +91 22 2763 7200 / +91 22 2760 0401
www.bharatbijlee.com

All product designations may be trademarks or product names of Bharat Bijlee Ltd, or of its partner or supplier companies, and whose use by third parties for their own purposes could violate the rights of the owners.

Product improvement is a continuous process and technical information herein is subject to change. Please contact our nearest sales office for the latest information.